



Frequently asked questions

DrillRight app

Introduction and explanation of the app.....	2
App Accuracy.....	5
Questions about the app start.....	6
Questions about placing the TV and the drilling hole in the app	9
Manual positioning	12



Introduction and explanation of the app

Q. How does the DrillRight app work?

A. The DrillRight app is a tool that helps you to hang your Vogel's TV mount. Step by step, we guide you through the installation process.

What makes it unique?

- The app shows you where to place the first drill hole. Initially, the app gives you a preview of how your TV will look on your wall from a distance.
- Using augmented reality, you can easily drag the TV to the desired position.
- Once you've chosen the spot, walk up to the wall to see the green marker. Trace it with a pencil. That's your first drill hole.

Q. Why do you have an app for hanging a TV mount?

A. We understand that hanging a TV mount doesn't happen often, especially considering the long lifespan of a Vogel's TV mount. That's why we've gathered as many conveniences as possible to guide you step by step.

For example, it's quite tricky and nerve-wracking to determine where to drill. The center of the wall plate may not necessarily be where the center of your TV will be. If you want to manually determine the position of the wall mount, you'll need to do quite a bit of measuring and calculating.

Additionally, in the DrillRight app, you can immediately see how your TV looks on your wall. There's a good chance that it will hang the way you want it after the first attempt!

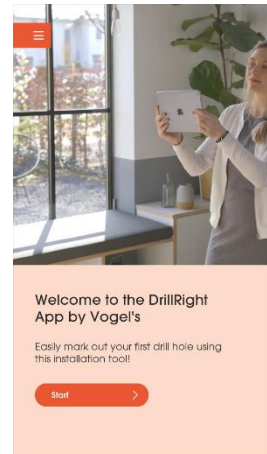



Q. How can I install the DrillRight app?

A. The DrillRight app can be downloaded on a phone or tablet as follows:

- Go to the [App Store](#) or [Play Store](#) and search for 'DrillRight', select and download the DrillRight app or
- Scan the QR code below (which you can also find on the card in the packaging) and download the app:



Requirements for using the app

Q. Which devices are compatible with the DrillRight app?

A. You can use the app with Android phones and tablets version 7.0 and newer, or iPhone 10 and newer. However, the newer your operating system, the better the app works.

Usually, the newer your phone is, the better the result. It's preferable to use the app with a phone that is no more than 3 years old. This ensures it's equipped with the best camera and sensors, resulting in a more precise drill hole.

Additionally, your phone must support "Depth API" to ensure cameras and sensors work well together. If your phone supports "Depth API," you'll see it in the "Comments" column in the [list of devices with "Depth API."](#)

If your device doesn't meet these requirements, the App Store or Play Store will indicate that the app is not compatible with your device, and you won't be able to download the app.



Q. Why can I only use the app if I have a solid concrete or brick wall?

A. In a solid concrete or solid brick wall, you don't need to worry about where you drill.

For a wall with wooden studs, you always need to drill into the studs. The app cannot detect where those studs are, so you cannot determine the first drill hole with it. However, you can still use the app to get an idea of how you want to position the TV. You will then need to move the drill hole to the nearest stud. If you don't want to consider the studs, you can purchase a stud adapter to position a full-motion mount freely on the wall.

For other types of walls (or if you're unsure of the wall type), we always recommend consulting a professional installer. It may be that you have a non-solid wall made of concrete or brick. In that case, the TV may not stay in place without proper preparation. You may need additional installation materials.

Q. What information do I need to use the DrillRight app?

- A.**
- You need to know what type of wall you have, as the app is only usable with solid walls.
 - Type of your TV mount. This allows the app to determine if it matches your TV. The app also knows which installation questions and videos are relevant.
 - Model of your TV. This lets the app know if your TV fits on the TV mount.
 - The app also asks you to measure the distance between the bottom of the TV and the bottom of the vertical strips, or between the top of the TV and the top of the strips. This is because you can usually mount them in different ways, and because the VESA holes can be at different heights. This way, the app knows how high the TV will be relative to the wall plate. It's handy if the app shows you what it will look like at your home.

That's it! The app will tell you what tools you need and the installation videos will help you through all the installation steps.



App Accuracy

Q. How accurate is the DrillRight app?

A. The DrillRight app displays the first drilling hole with a maximum deviation of 3 cm. The latest devices provide the most accurate results. Therefore, always choose the newest phone available when using the app.

Factors that ensure the best result:

- Reference points on the wall, such as patterned wallpaper or post-its
- Well-lit room
- Measure the result afterward for extra accuracy

Q. How accurate is the spirit level in the DrillRight app?

A. It depends on the sensors in your phone, but most phones can indicate fairly accurately whether your TV is level. Make sure there are no cases or buttons obstructing. Mount your TV level in a position parallel to the wall.

Questions about the app start

Q. My TV mount and TV are not a match according to the app. What should I do?

- A.** There are 3 factors that need to match to have a match:
1. The VESA pattern (the mounting holes on the back of your TV)
 2. The height of the TV
 3. The weight of the TV.

If any of the three is not a match, you need to choose a different mount.

If the app says your TV is not a match with your mount, but these 3 requirements are met, click on "my TV is not listed" on the TV selection screen and fill in this information. If that leads to a match, you can proceed directly in the app.

Still no match? Is it not clear why it's not a match, or do you think the mismatch is incorrect? Send us a message via drillright@vogels.com.



Q. Why do I need these tools?

A. The tools list varies depending on the TV mount. But generally, you need the following items for various reasons:

- **Drilling machine**, of course, to make the holes in the wall. It's wise to also have a vacuum cleaner handy to catch the dust and vacuum out the holes.
- **Pencil**, used to mark the drilling hole recommended by the DrillRight app.
- **Tape measure** to measure the distance from the strips to the bottom of the TV.
- **Masking tape** to hang the DrillRight poster on the wall without damaging it.
- **Scissors** to cut out the drilling template. In the case of a large insert card, you can also cut out the poster.
- **Large crosshead (Phillips) screwdriver** to screw the bolts of the vertical strips into the TV.
- **Socket wrench**: We use hex bolts for mounting the wall plate to the wall because they get tighter in the wall than Phillips bolts (which can slip). You can also use a socket bit and attach the bolts to the wall with an electric screwdriver.
- **Allen key**: For some full-motion models, you use an Allen key to tighten the parts attached to the TV to the wall mount. Some models also have adjustment options that you set with an Allen key. Refer to the full manual at www.manuals.vogels.com for this.
- **1 or 2 sizes of concrete/stone drill bits**. If two drill bit sizes are listed, use the smallest one for pre-drilling.

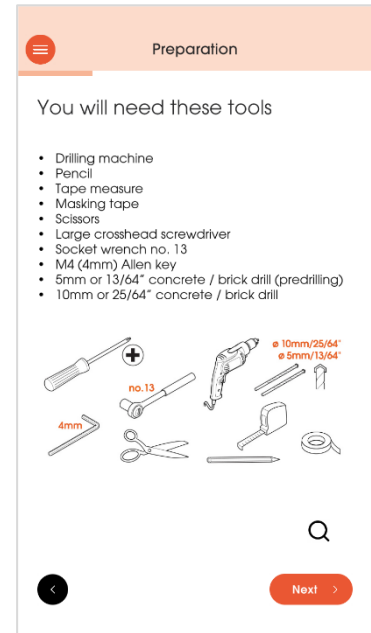

Q. Why does the app ask where the connections on my TV are?

A. If your TV connections are on the left, then with a full-motion TV mount, it's best to fold the arm to the right when pushing the TV against the wall. Most full-motion TV mounts are not symmetrical. Therefore, the direction in which you fold the arm affects where you need to drill.

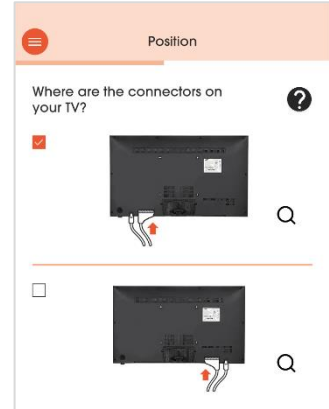

Q. Why do I need to be aware of the surroundings when using Augmented Reality?

A. If you're focused on your screen and walking through the space at the same time, accidents can happen. Be sure not to trip over objects or furniture and avoid bumping into anything.

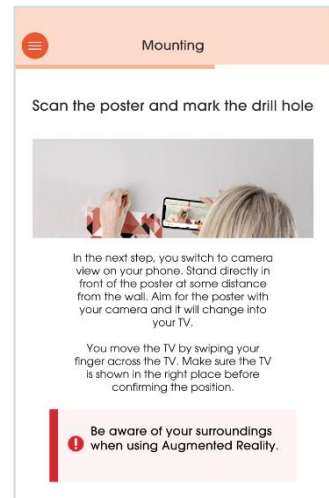

Q. What is the poster for?

A. The poster serves as a visual reference that tells the app how large the wall is and where the phone is located relative to the wall. This way, the app knows how large the projection of your TV should be, and you can also move around the room during this step. Also important: as you get closer to the wall to mark your drilling hole, the app uses the poster as a reference point for the chosen TV placement.

Questions about placing the TV and the drilling hole in the app

Q. The app says "Scan the poster" but nothing happens, what should I do?

A. If everything has been done correctly, you should have hung the poster that came in the packaging on the wall, approximately where you want to hang the TV. Is your poster not turning into a TV on your screen? Make sure there is enough light in the room. Move closer or further away from the poster with your camera focused on it. Or briefly point it at the ground and try again. If the app successfully scans your poster, the poster on your screen will turn into a black rectangle, and you will proceed to the next instruction: "Drag the TV to the desired location."

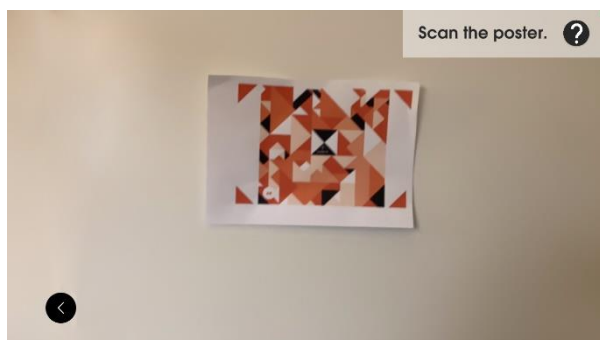

Q. The app says "Drag the TV to its final position." What should I do?

A. Move the TV by swiping your finger across the screen. This allows you to choose the best spot for the TV in your room. You can move the TV up, down, and sideways. The indicated drilling point in the next step will be adjusted accordingly. Are you satisfied? Click on "Confirm TV position."

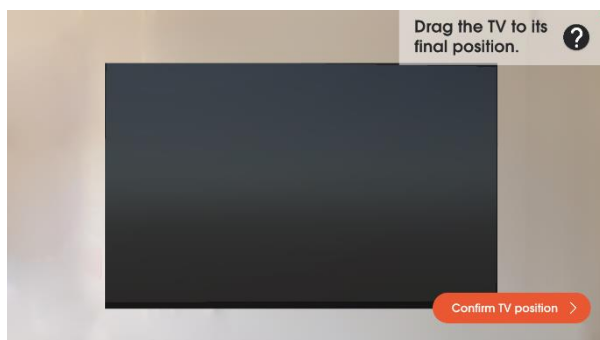

Q. The app says "Oops! The poster is not visible enough". What should I do?

A. The camera needs to register the poster properly in order to project the TV at the right spot and indicate the correct drilling point there.

This means that the majority of the poster should be visible on your device's screen. Even when you move closer to the wall to mark the drilling hole. If your planned drilling point is not near the poster, you can move the poster closer to the hole and try the previous step again.

If the resolution of your camera is not very high or if the room is too dark, the app may also have difficulty finding the poster.

Do you expect the app to see the poster but the message remains? Then aim briefly at the ground and try again. Moving forward or backward can also help. If that doesn't work, go back a step in the app or restart the app.

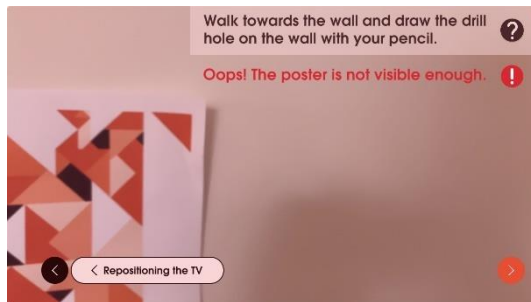

Q. My drilling hole wobbles a little. How can that be?

A. With some Android devices, the drilling hole may wobble a little when you move towards the wall. However, the drilling hole should always return to the same spot.

If the drilling hole really doesn't stay in place or if the wall plate is crooked, there may have been an issue determining the position of the poster. You can go back a step in the app or restart the app to try again.





- Q. My poster is in the way of my first drill hole, what now?**
A. No problem, it's just paper! Simply mark it and drill through the poster.

- Q. I've drilled my first hole, and now?**
A. Place the drilling template provided in the box horizontally on the wall, and you'll know where your other holes should be! Of course, we'll also guide you through this step in the app. You can follow the short instructional video or use the [comprehensive online manual](#).

- Q. My TV isn't hanging where I placed it with the DrillRight app, how can that be?**
A. The DrillRight app is a technical tool, and caution is advised when using it. Before drilling, carefully check if the drill markings are in a logical position, for example, by holding the TV in front of them.

Although the DrillRight app has been developed and tested with care and there are tens of thousands of TVs in our database, with more added daily, it's impossible to anticipate all possible usage scenarios.

Do you believe there's an error in the app or are you having trouble? Please contact us at drillright@vogels.com.

- Q. What is augmented reality?**
A. *Augmented Reality* means enhanced reality. Your phone or tablet adds an element to the camera image you see on your screen. In this case, a TV or drilling template is projected onto your wall. This allows you to see how your wall would look with the TV on it before drilling holes.

For other issues/questions, please contact: drillright@vogels.com

Manual positioning

Q. I'm having trouble with the app. How do I manually determine the position for my TV mount?

A. Fixed and tiltable mounts - Horizontal position

Mount the wall plate precisely in the horizontal center of where your TV should go. That's easy.

Fixed and tiltable mounts - Vertical position

The quickest way to determine the ideal height of a fixed or tiltable TV mount is as follows:

- **X:** Mount the strips on the back of your TV according to the instructions. While the TV is still on the floor, click the wall plate into the strips. Measure the distance from one of the drill holes to the bottom of your TV.
- **Y:** The distance from the bottom of the TV to the floor (or TV cabinet). The middle of the TV should be approximately at eye level when you're sitting on the couch.
 - With modern TV technologies, it's fortunately not so important whether you view the TV from an angle. So you can also hang it a bit higher or lower if it looks better.
 - Tiltable mounts can be hung above eye level. Here too, the exact angle no longer matters. Position the TV where it doesn't obstruct.

Mark the drill hole at X+Y height above the floor (or TV cabinet).

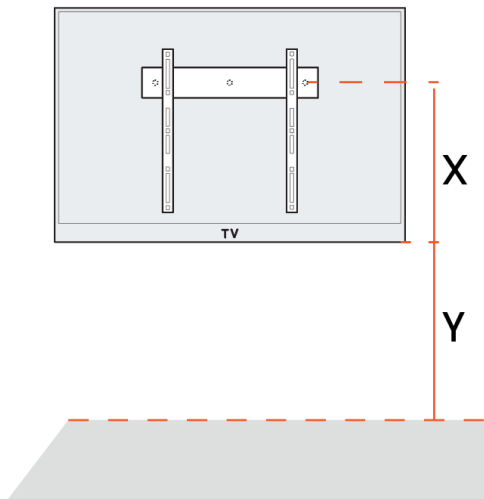

Full-motion TV mount - Horizontal position

Most drill holes do not come exactly in the horizontal center of your TV. You can find how far they are from the center in the [online manual](#) (under step 2 "Solid concrete or brick wall") or in the table on the following page.

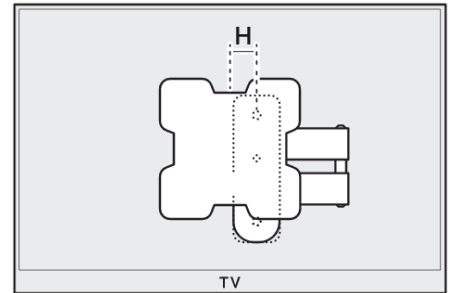

Full-motion TV mount - Vertical position

You need 3 measurements to mark the height of the drill hole:

- A: The distance from the top drill hole to the bottom of the vertical strip. This distance depends on the mount you have and is listed in the table on the next page.
- B: The distance from the bottom of the vertical strip to the bottom of the TV. You can measure this with a tape measure after mounting the vertical strips to the TV.
- C: The distance from the bottom of the TV to the floor (or TV stand). The middle of the TV should be approximately at eye level when you're sitting on the couch.
 - With modern TV technologies, fortunately, it doesn't matter much if you view the TV from an angle. Therefore, you can also hang it slightly higher or lower if it looks better.

Mark the drill hole at $A+B+C$ height above the floor (or TV stand).

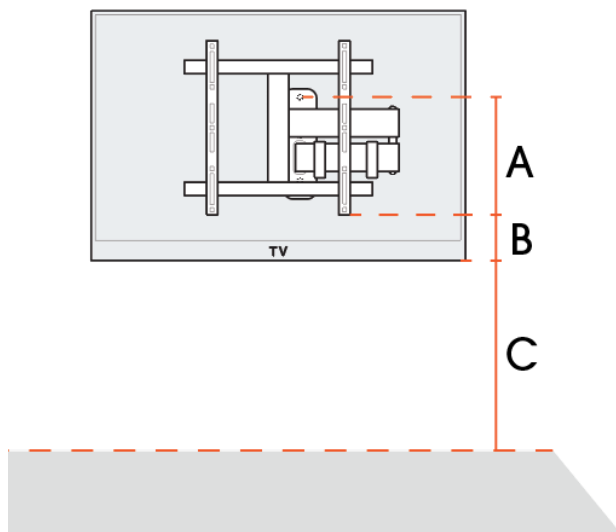

Table with sizes

TV mount	Dimension A	Dimension H
TVM 1200/3200 series	137 mm	0 mm
TVM 1210 series	114 mm	0 mm
TVM 3210 series	170 mm	0 mm
TVM 1400/3400 series	337 mm	0 mm
TVM 1410/1610 series	114 mm	0 mm
TVM 3410/3610 series	170 mm	0 mm
TVM 1600/3600 series	337 mm	0 mm
TVM 1220 series	254 mm	192 mm
TVM 1240 series	179 mm	45 mm
TVM 1420 series	354 mm	237 mm
TVM 1440 series	272 mm	45 mm
TVM 1620 series	373 mm	282 mm
TVM 1640 series	281 mm	45 mm
TVM 3220 series	238 mm	237 mm
TVM 3240 series	165 mm	45 mm
TVM 3420 series	371 mm	282 mm
TVM 3440 series	281 mm	45 mm
TVM 3620 series	386 mm	327 mm
TVM 3640 series	295 mm	45 mm
TVM 3840 series	365 mm	45 mm
TVM 5400/5600 series	368 mm	0 mm
TVM 5440/5640/5840 series	374 mm	45 mm
TVM 5850 series	301 mm	0 mm

